

LM20 Microfluidizer™ High Shear Fluid Processor

Digitally Controlled, Electric Power, Lab Unit For Small Sample Processing

Microfluidizer™ technology converts fluid pressure more efficiently into shear forces, leading industry performance standards in high pressure homogenization.

A unique solution to maintaining consistent process pressure, ensures 100% of your material gets exactly the same treatment. So whether you are working with small lab samples or production volumes, the Microfluidizer™ is unmatched in creating sub-micron emulsions, high yield cell disruption and guaranteed process scale-up.

Recommended For:

- Emulsions
- Dispersions
- Liposomes
- Cell Disruption
- Fine Particle Deagglomeration



Model shown is subject to change depending on options selected

Unique Benefits of the LM20

- Achieve unmatched size reduction/disruption performance at lower process pressure
- Limit sample temperature rise during processing
- Higher product yields after sterile filtration with tighter particle size distribution
- Save on development time in pilot/production with linear volumetric scale-up
- Enhanced repeatability with easy-to-use digital pressure control
- Compact design to fit in a fume hood
- Ensure dependable process performance over time with maintenance reminder and operator alerts
- Adapt to future experimentation possibilities with field upgradable firmware

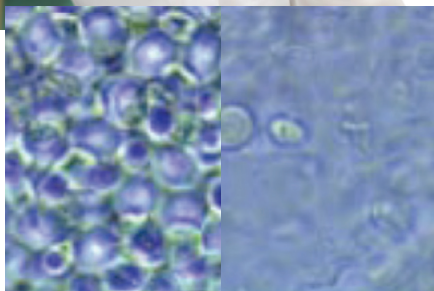

Before Processing

After Processing

Highest efficiency cell disruption with minimal denaturation.

P. pastoris
>95% disruption,
1 pass, 30,000psi.

Operating Principle

The LM20 contains an intensifier pump designed to supply the desired pressure at a constant rate to the product stream. As the pump travels through its pressure stroke, it drives the product at constant pressure through precisely defined fixed-geometry microchannels within the interaction chamber.

As a result, the product stream accelerates to high velocities, creating shear rates within the product stream that are orders of magnitude greater than any other conventional means. All of the product experiences identical processing conditions, producing the desired results, including: uniform particle and droplet size reduction (often submicron), deagglomeration and high-yield cell disruption.

Standard Features

- 300 ml glass reservoir
- Diamond interaction chamber assembly (Ceramic interaction chamber for LM20-20 model)
- Digital pressure control
- Integrated stroke counter with maintenance reminder
- Multiple languages (selectable by user)

Options

- Auxiliary Processing Modules (APMs)
- Cooling coil and chilled bath assembly
- Process fluid recirculation assembly/kit
- Process pressure gauge
- Larger capacity glass or stainless steel reservoirs
- Solvent-resistant gasket materials

Specifications

Pressure Range	Up to 30,000 psi (2068 bar)*
Minimum Sample Size	14 ml
Flowrate Range	60 - 100 ml/min
Feed Temperature	Maximum of 165°F (75°C)
Electrical Power Requirement	208-230/460V, 60Hz, 3PH (190-220/380-415V, 50Hz, 3PH)
Pump Actuator	Electro-hydraulic
Noise Level	<80dB TWA
Dimensions	23"H x 33"W x 26"L (58cm x 84cm x 66cm)
Weight	250 lbs (114 kg)

*20,000 psi for LM20-20 model

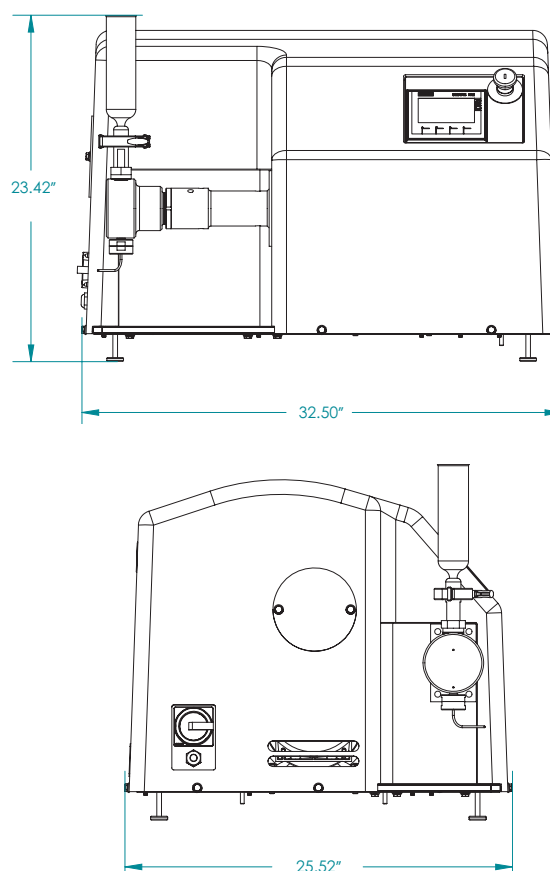

*Dimensions Are Approximate

Microfluidics

Microfluidics International Corporation
90 Glacier Drive, Suite 1000 • Westwood, MA 02090, USA
Tel: 617-969-5452 • 800-370-5452 • Fax: 617-965-1213
Email: mixinginfo@idexcorp.com • www.microfluidicscorp.com

Bramley Drive, Vale Park West, Evesham, Worcestershire, WR11 1JH, UK
Tel: (+44) (0) 1386 769 007 • Fax: (+44) (0) 870 1911116
Email: mixinginfo@idexcorp.com • www.microfluidicscorp.com



©2015 by Microfluidics. All rights reserved. 05/15 IH .5K